

*Synthesized  
Base Station  
Transmitter*



**COMTEK®**

# INTRODUCTION

---

---

## **BST 25-216** *Synthesized Base Station Transmitter*

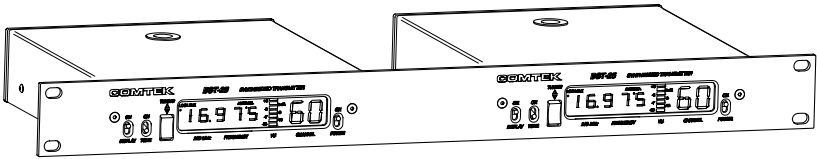

The **BST 25-216** is a professional quality, auxiliary base station transmitter designed to operate with the PR-216 and PR-216 Option 7 synthesized receivers in the 216-217 MHz band, and is granted under FCC Parts 22, 74, and 90. This transmitter may be used for personal cueing, for tour guide applications, language interpretation, and for assistive listening. For highest fidelity operation, the PR-216 receiver must be used with the wide-band companded channels.

The BST 25-216 also operates with the Phonak microEar VHF in-ear receiver in the narrow-band non-companded channels.

The BST 25-216 transmitter incorporates the latest digital and analog technologies to produce low residual noise, wide dynamic range, and extended frequency response rendering the most natural sound possible from a wireless system.

# OPERATING INSTRUCTIONS

---

## Equipment Placement

If the BST 25-216 base station is to be rack-mounted, a remote antenna must be used. The base station should be mounted away from equipment that uses large power transformers to reduce 60 Hz hum possibilities.

If the base station is to be used outside of a traditional rack-mounted environment, the screw-in whip antenna should be free of any metallic objects when fully extended (12 1/2 inches).

**Special Note:** When using the base station in close proximity to other audio equipment, ensure that the audio equipment is not susceptible to RF interference. This can be accomplished by temporarily installing the base station as per above, and then while the base station is operating, checking all audio outputs for uncharacteristic noise. If a problem is found, move the base station or the remote antenna as far as possible from the affected equipment. Should you continue to have problems, contact COMTEK's application engineering department for assistance.

## Remote Antenna

When the base station is rack-mounted or when greater system range is required, a remote antenna should be used. For vehicle installation, a 1/4 wave roof-mount (MO-1/4 wave or MAG-1/4 wave) should be used. For field or studio applications, the COMTEK "Phase Right Antenna" (PRA-H 216 MHz) is an easy-to-use, high performance, omni antenna. For high gain directional yagi type antennas and custom antennas, contact COMTEK's application engineering department for assistance.

*Please note: Do not install screw-in whip antenna if remote antenna is used.*

---

---

## Power Requirements

The BST 25-216 base station is designed to be powered by 12 volts DC. A power adaptor is furnished for use with standard 110V AC. The on/off switch on the front panel of the base station turns on the transmitter.

## Audio Input Connections

The base station transmitter has facilities for audio input from a mic, line, or speaker level source. The mic/line level audio input is a transformer balanced input and requires a standard XLR-3 male connector. Unbalanced input is accomplished by shorting pin-3 to pin-1 (audio ground), leaving pin-2 as the audio source. *Please note: when unbalanced input is used, it is recommended that all audio input cables be kept as short as possible.*

## Set-up

- a. Select an appropriate location for the base station in accordance with "Equipment Placement" instructions.
  
- b. Set the "MIC/LINE" switch, located on the back of the base station transmitter, to the appropriate position: "MIC" position for low impedance microphones or "LINE" position for line level feed.
  
- c. Connect the audio source or microphone to the base station using the appropriate input. Be sure to set the audio input level adjustment on the base station to its full counterclockwise position.

## OPERATING INSTRUCTIONS (continued)

---

d. Plug the adaptor into a standard AC outlet and plug the power connector into the DC input jack of the transmitter. Turn the display switch on the front of the transmitter "ON" to allow monitoring of the transmitter frequency. Turn the main power switch on the front of the base station to the "ON" position. The front display should now be illuminated.

e. Mount the telescoping whip antenna in the hole on top of the base station rotating it clockwise until it is firmly seated. Extend the antenna completely (12 1/2 inches). During normal operation the antenna indicator should not flash. Turn on the transmitter and verify that the antenna indicator is not flashing. If the antenna indicator is flashing, it is an indication that the antenna is not fully efficient. The antenna should be checked for appropriate length, antenna elements in too close proximity to metallic objects, or for a damaged coaxial cable to remote antenna. Also, **DO NOT** install screw-in whip antenna if remote antenna is used.

### Audio Adjustments

In order to ensure the highest possible transmission fidelity, the transmitter must be modulating at least 50% with normal speech (-3 dB on the VU meter). This adjustment is made in the following manner:

---

---

a. Ensure that the audio source has been optimized for best signal-to-noise ratio.

b. The “MIC/LINE” switch located at the back of the transmitter should be switched to the appropriate setting: “MIC” for mic level or weak line level input; “LINE” level for line level input.

c. The “LEVEL” control on the back of the base station should be set fully counterclockwise and then, while normal program information is present, slowly rotate the “LEVEL” control clockwise until the VU meter on the front panel begins to deflect. Adjustment should be made so that normal speech or music deflects the meter mid-scale. Only very loud speech or music should deflect the VU meter full-scale.



## Frequency Selection

The BST 25-216 MHz base station transmitter can operate on 60 channels between 216 MHz and 217 MHz. Channels 1-40 are narrow-band channels for use with the Phonak microEar receiver with 5 KHz deviation. Channels 41-60 are wide-band channels for use with COMTEK PR-216 receiver with 10 KHz deviation. The PR-216 will tune the Phonak microEar channels 1-40 but with lesser fidelity. Refer to page 10 for Channel/Frequency Chart.

## Multiple Channel Operation

Simultaneous operation of more than two channels requires coordination of the frequencies that are used to avoid intermodulation interference.

## **OPERATING INSTRUCTIONS** (continued)

---

To avoid this type of interference, select frequencies from one of the standard groups (see frequency group charts on page 11), or use COMTEK's frequency selection guide software to determine appropriate frequencies. (Contact COMTEK to obtain a free copy of the frequency selection software.)

### **Test Tone**

The BST 25-216 base station transmitter has an internal 400 Hz source which is transmitted when the "TONE" switch is enabled. This source is intended to be used to make technical adjustments and to verify the operation of the system. Under normal operation the "TONE" switch should be disabled.

### **Speech EQ**

On the back of the transmitter there is a switch labeled "EQ". With this function enabled (switch up), the audio dynamics and frequency response are processed to improve intelligibility of speech. If the primary audio source is going to be speech, you should enable this processing. If the main audio source is going to include music information, you should disable it. You may want to experiment to determine which position sounds most pleasing with the program source you intend to use.

---

---

## Display On and Off

The digital display can be turned on or off using the “DISPLAY” switch. Disabling the display reduces the current consumption of the transmitter for battery operation. In environments where the display could be distracting, disabling the display may also be appropriate. When the display is disabled, the tuning controls are also disabled, ensuring the transmitter frequency is not changed inadvertently. With the display disabled, one segment is turned on as a power indicator. Additionally, the “LOCK OUT” indicator is illuminated indicating the tuning is disabled. The VU meter and the “ANTENNA” indicator are unaffected.

## Lock Out

After the transmitting frequency has been determined, the transmitter tuning function can be disabled with the “LOCK OUT” switch on the back of the transmitter. This ensures that the transmitter operating frequency is not inadvertently changed. The “LOCK OUT” indicator (above the first numeric digit on the display) will illuminate indicating that the tuning has been disabled. When rack-mounting the transmitter this switch must be accessed from behind the rack. This provides added protection from tampering.



## BST 25-216 FRONT PANEL

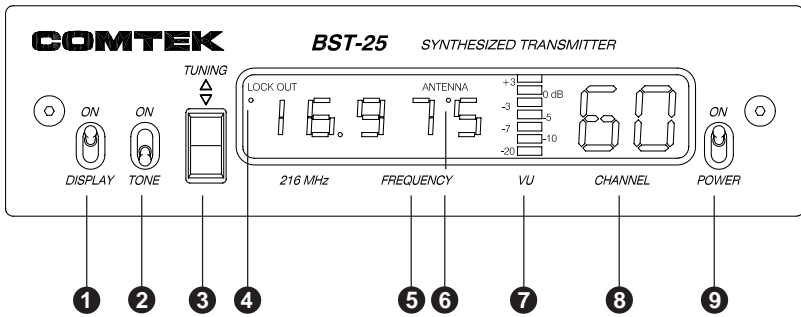

- 1 DISPLAY SWITCH:** This switch disables the digital display to conserve current when used with a battery.
- 2 TONE SWITCH:** Enables/disables the internal 400 Hz test tone.
- 3 TUNING SWITCH:** Selects the frequency on which the transmitter will operate.
- 4 LOCK OUT INDICATOR:** Illuminates when the "TUNING" switch is disabled by setting the "LOCK OUT" switch (rear panel) to "ON".
- 5 DIGITAL FREQUENCY DISPLAY:** Displays the frequency on which the transmitter is operating.
- 6 ANTENNA INDICATOR:** Flashes when the transmitter senses a deficient antenna condition.
- 7 VU METER:** Displays the level of audio being transmitted. Used to adjust the "LEVEL" (rear panel) control.
- 8 DIGITAL CHANNEL DISPLAY:** Displays the channel on which the transmitter is operating.
- 9 POWER SWITCH:** Turns the transmitter on or off.

## BST 25-216 REAR PANEL

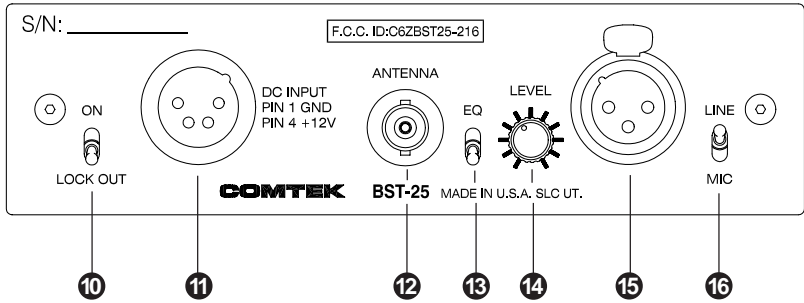

- 10 LOCK OUT SWITCH:** Disables the front panel "TUNING" switch, locking the transmitter on one frequency.
- 11 DC INPUT JACK:** Requires 12 VDC at 500 mA source (Pin-1 ground, pin-4 +12 volts).
- 12 EXTERNAL ANTENNA JACK:** BNC connector provides a standard 50 ohm RF output for use with an external antenna.
- 13 SPEECH ENHANCEMENT SWITCH:** Enables and disables speech enhance feature. Enable this function (switch up) for speech, and disable it (switch down) for music.



*For use with Phonak's or COMTEK IR-230, the EQ switch should be in the "up" position.*

- 14 LEVEL CONTROL:** This control should be adjusted so that normal audio deflects the VU meter to midscale.
- 15 BALANCED AUDIO INPUT:** Accepts audio from a line level or dynamic microphone (Pin-1: ground).
- 16 MIC/LINE SWITCH:** Selects the desired audio input sensitivity.

# BST 25-216

216 MHz

## FREQUENCY CHART

CHANNEL	FREQUENCY
NARROW-BAND CHANNELS For use with COMTEK and other manufacturers	
1	216.0125 MHz
2	216.0375 MHz
3	216.0625 MHz
4	216.0875 MHz
5	216.1125 MHz
6	216.1375 MHz
7	216.1625 MHz
8	216.1875 MHz
9	216.2125 MHz
10	216.2375 MHz
11	216.2625 MHz
12	216.2875 MHz
13	216.3125 MHz
14	216.3375 MHz
15	216.3625 MHz
16	216.3875 MHz
17	216.4125 MHz
18	216.4375 MHz
21	216.5125 MHz
22	216.5375 MHz
23	216.5625 MHz
24	216.5875 MHz
25	216.6125 MHz
26	216.6375 MHz
27	216.6625 MHz
28	216.6875 MHz
29	216.7125 MHz
30	216.7375 MHz
31	216.7625 MHz

CHANNEL	FREQUENCY
32	216.7875 MHz
33	216.8125 MHz
34	216.8375 MHz
35	216.8625 MHz
36	216.8875 MHz
37	216.9125 MHz
38	216.9375 MHz
39	216.9625 MHz
40	216.9875 MHz
WIDE-BAND CHANNELS For use with COMTEK equipment only	
41	216.0250 MHz
42	216.0750 MHz
43	216.1250 MHz
44	216.1750 MHz
45	216.2250 MHz
46	216.2750 MHz
47	216.3250 MHz
48	216.3750 MHz
49	216.4250 MHz
51	216.5250 MHz
52	216.5750 MHz
53	216.6250 MHz
54	216.6750 MHz
55	216.7250 MHz
56	216.7750 MHz
57	216.8250 MHz
58	216.8750 MHz
59	216.9250 MHz
60	216.9750 MHz

**BST 25-216**  
 216 MHz  
 NARROW-BAND  
 FREQUENCY GROUPS  
 Compatible with COMTEK  
 and other manufacturers  
 (5 kHz deviation)

**GROUP A**

CHANNEL	FREQUENCY
1	216.0125 MHz
9	216.2125 MHz
15	216.3625 MHz
24	216.5875 MHz
31	216.7625 MHz
36	216.8875 MHz

**GROUP B**

CHANNEL	FREQUENCY
4	216.0875 MHz
10	216.2375 MHz
14	216.3375 MHz
32	216.7875 MHz
35	216.8625 MHz
40	216.9875 MHz

**GROUP C**

CHANNEL	FREQUENCY
3	216.0625 MHz
5	216.1125 MHz
12	216.2875 MHz
22	216.5375 MHz
38	216.9375 MHz

**GROUP D**

CHANNEL	FREQUENCY
17	216.4125 MHz
23	216.5625 MHz
30	216.7375 MHz
34	216.8375 MHz
39	216.9625 MHz

**BST 25-216**  
 216 MHz  
 WIDE-BAND  
 FREQUENCY GROUPS  
 For COMTEK  
 equipment only  
 (10 kHz deviation)

**GROUP 1**

CHANNEL	FREQUENCY
41	216.0250 MHz
44	216.1750 MHz
51	216.5250 MHz
55	216.7250 MHz
60	216.9750 MHz

**GROUP 2**

CHANNEL	FREQUENCY
42	216.0750 MHz
49	216.4250 MHz
53	216.6250 MHz
58	216.8750 MHz

**GROUP 3**

CHANNEL	FREQUENCY
43	216.1250 MHz
46	216.2750 MHz
51	216.5250 MHz
57	216.8250 MHz

**GROUP 4**

CHANNEL	FREQUENCY
44	216.1750 MHz
47	216.3250 MHz
54	216.6750 MHz
59	216.9250 MHz

# BST 25-216 INTERNAL ADJUSTMENTS (216 MHz)

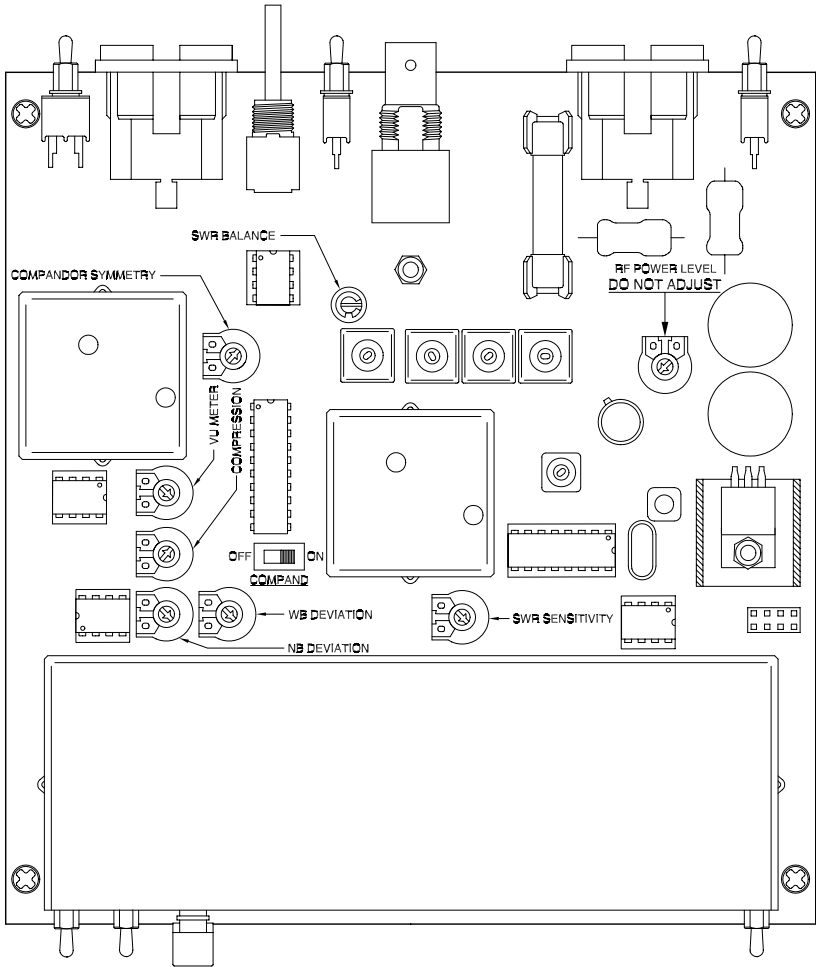

**NOTE:** The Compand Switch must be set to the "ON" position for automatic companded and non-companded operation with channel selection. The "OFF" position is only used for testing.

# BST 25-216 ACCESSORIES

---

## Included Accessories

1. C-16 Carrying case
2. BST 25-216 Operator's manual
3. TWA-72 Whip antenna
4. BST 25-216 Base station transmitter
5. AP-12V1 Power adaptor (115 VAC Input)

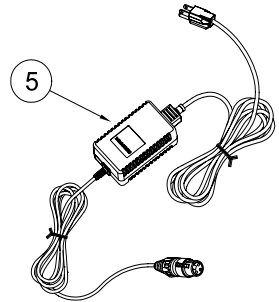
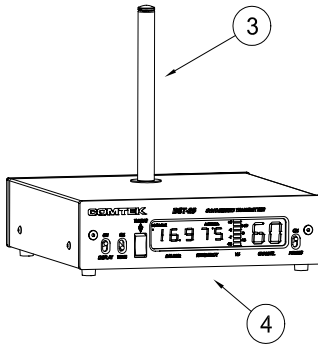
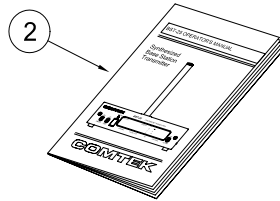
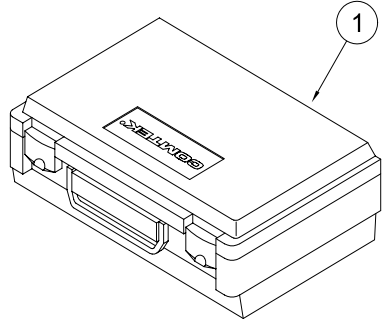

Optional Accessories

- 1. RDA-2 Remote dipole antenna
- 2. PRA Phase-Right coaxial antenna
- 3. MO-1/4 wave vehicle installation antenna or MO-1/4 wave magnetic mount antenna
- 4. PRA Phase-Right antenna mount
- 5. RMK 25 Single rack-mount face plate
- 6. RMK 25-2 Double rack-mount face plate

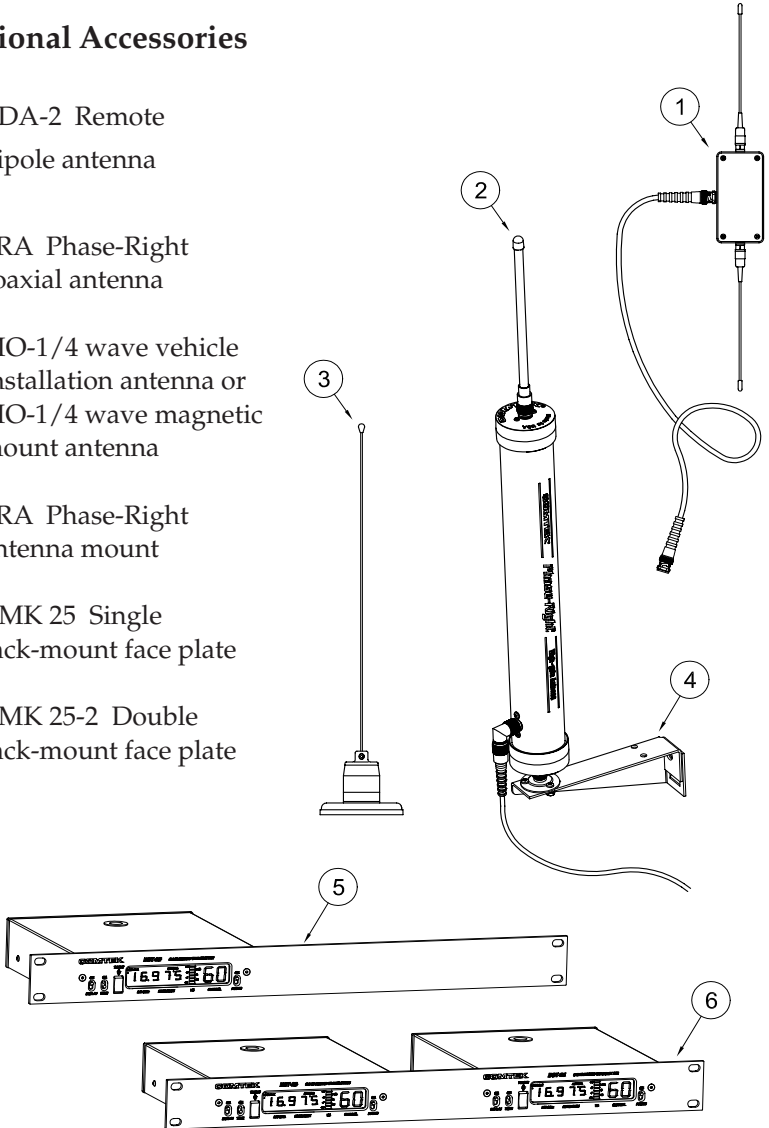

# BST 25-216 SPECIFICATIONS

---

## Audio Inputs:

- Mic XLR, 600 ohm Balanced -40 dBV (nominal)
- Line XLR, 10 k ohm Balanced 0 dBV (nominal)

## Connectors:

- XLR-3 Female audio input connector for mic and line input
- XLR-4 Male power input 12 volts
- BNC type RF output connector

## Operation Indicators:

- LED Bargraph VU Meter displays audio input (modulation)
- Two-Digit Alpha Numeric Display shows operating channel
- Five-Digit Numeric Display shows operating frequency
- Antenna Indicator displays deficient antenna condition
- Lock Out Indicator shows tuning has been disabled

## Antenna:

- Telescopic antenna mounts directly into top of transmitter
- BNC RF output connector for optional external antenna

## FCC Compliance:

FCC Parts 22, 74, and 90

## Power Requirements:

12 Volts DC, 300 mA max

## Frequency Response:

80 Hz to 10 kHz

## Audio Distortion:

Less than 1% at 80% modulation

## Modulation Limiter:

Soft compressor type with high (25 dB) linear overload protection, attack time less than 1 ms, recovery time 10 ms

## Audio Gain Control:

Greater than 40 dB

## Test Tone Generator:

400 Hz 0.05% distortion

## Frequency Modulation:

5 and 10 kHz deviation

## RF Output Power:

Set for 100 mW

## Frequency Stability:

Better than 20 ppm. digitally synthesized, crystal controlled

## Operating Frequency:

216 to 217 MHz

## Harmonic and Spurious

### Emissions:

Better than 55 dB below carrier

### Dimensions:

6 1/2" wide x 1 3/4" high x 5 5/8" deep

### Weight:

44 oz.

NOTE: Specifications subject to change without notice



# WARRANTY AND SERVICE

---

## Warranty

COMTEK transmitters and receivers are warranted to be free from defects in workmanship and material under normal stand-alone use and conditions for a period of **two years** from date of original purchase. Items such as headphones, earphones, neckloops, and cords are warranted to be free from defects in workmanship and material for a period of 90 days from the date of original purchase. Batteries are not covered by this warranty. Damage due to abnormal use, extreme conditions, misuse, use of the product as a component of another product, ill treatment and unauthorized modification and repairs are not covered by this warranty. COMTEK is not liable for any consequential or punitive damages arising out of any failure of the equipment to perform as intended. COMTEK shall bear no responsibility or obligation with respect to the manner of use of any equipment sold by it. COMTEK SPECIFICALLY DISCLAIMS AND NEGATES ANY WARRANTY OF MERCHANTABILITY OR FITNESS OF THE PRODUCT FOR A PARTICULAR PURPOSE INCLUDING, WITHOUT LIMITATION, ANY WARRANTY THAT THE USE OF SUCH EQUIPMENT FOR ANY PURPOSE WILL COMPLY WITH APPLICABLE LAWS AND REGULATIONS.

## Service Policy

Warranty repairs must be done by COMTEK. Only factory technicians are authorized to perform warranty service on the BST 25-216 transmitter. Before returning the BST 25-216 for service, a Return Authorization Number should be obtained from the service department by calling 1-800-496-3463 or 1-801-466-3463. Return the unit to the factory with the original or comparable packing. COMTEK will pay for insurance and ground return shipping costs in the United States for all warranty service.

# COMTEK®

357 West 2700 South • Salt Lake City, Utah 84115 • Phone: (800) 496-3463 • Fax: (801) 484-6906 • [www.comtek.com](http://www.comtek.com)  
E-mail: [sales@comtek.com](mailto:sales@comtek.com)

---

---

# COMTEK®

357 West 2700 South • Salt Lake City, Utah 84115 • Phone: (800) 496-3463 • Fax: (801) 484-6906 • <http://www.comtek.com>